

INSTRUCTION MANUAL

(For Professional Use Only)

HIGH VOLUME LOW PRESSURE COMPRESSED AIR SPRAY GUNS

DO NOT USE SPRAY GUNS BEFORE READING THIS MANUAL



8000



8200



8400

This manual contains important warnings and instructions.

TABLE OF CONTENTS

WARNINGS AND CAUTIONS	3
GENERAL INFORMATION	4
IDENTIFY SPRAY GUNS	4
OPERATING INSTRUCTIONS MODEL 8000	4
A8000 HVLP SPRAY GUN MAINTENANCE	5
OPERATING INSTRUCTIONS HVLP SPRAY GUN MODEL 8200 (TRI-MODE)	6
A8200 HVLP SPRAY GUN MAINTENANCE	7
OPERATING INSTRUCTIONS HVLP SPRAY GUN MODEL 8400 (TRI-MODE)	8
A8400 HVLP SPRAY GUN MAINTENANCE	9
DIAGRAM A 8000 HVLP SPRAY GUN.....	10
DIAGRAM B 8200 HVLP SPRAY GUN.....	11
DIAGRAM C 8400 HVLP SPRAY GUN	12
OPTIONAL ACCESSORIES	13
DIAGRAM D SPRAYING TECHNIQUE	13
TROUBLE SHOOTING.....	14
SERVICE AND MAINTENANCE	14

WARNING

DO NOT USE EQUIPMENT BEFORE READING THIS SECTION

A fire or explosion hazard is present when spraying flammable materials. In order to assure safe operation of your spray system, please read the following instructions carefully.

- Always follow coating or solvent manufacturers safety instructions and warnings.
- Always spray in a well-ventilated area.
- Always keep the turbine system at the maximum length of hose.
- Always wear eye protection and a respirator.
- Always store indoors, never allow unit to freeze.
- Always use original manufacturers replacement parts
- Never spray flammable materials near open flames, pilot lights or any other source of ignition.
- Never alter or modify any part of this equipment; doing so can cause equipment malfunction and/or bodily injury.

Never leave spray equipment unattended. Keep away from children or any person not familiar with spray equipment.

Never aim spray guns at yourself, people or animals. Solvents and thinners can cause injury. Prior to any repair work the unit must always be disconnected from air pressure outlet. During painting, no open fire or lit cigarettes. Non-explosion proof bulbs and fixtures must exist if combustible fumes are present. During painting, breathing masks conforming to regulations must be worn for health protection.

FIRE OR EXPLOSION HAZARD

FLUID SECTION - SOLVENTS

Halogenated Hydrocarbon solvents can cause an explosion when used with aluminum or galvanized components in a closed (pressurized) fluid system (pumps, heater, filters, valves, spray guns, tanks, etc.). The explosion could cause serious injury, death and/or substantial property damage. Cleaning agents, coatings, paints, etc. may contain Halogenated hydrocarbon solvents. The manufacturer of this equipment uses aluminum components that will be affected by Halogenated Hydrocarbon solvents. **DO NOT USE HALOGENATED HYDROCARBONS WITH THIS EQUIPMENT.**

EXPLANATION OF THE HAZARD

There are three key elements to the Halogenated Hydrocarbon (HHC) solvent hazard. These elements are:

1. The presence of HHC solvents
2. Aluminum or galvanized parts
3. Equipment capable of withstanding pressure

When all three elements are present, the result can be an extremely violent explosion. The reaction can be sustained with very little aluminum or galvanized metal; any amount of aluminum is too much. The reaction is unpredictable. Prior use of an HHC solvent without incident (corrosion or explosion) does NOT mean that such use is safe.

HALOGENATED SOLVENTS – definition: Any hydrocarbon solvent containing any of the elements as listed below: Consult your material supplier to determine whether your solvent or coating contains Halogenated Hydrocarbon Solvents.

Fluorine (F) “-fluor-”
Bromine (Br) “-bromo-”
Examples (not all-inclusive):
FLUOROCARBON SOLVENTS:
Dichlorofluoromethane
Trichlorofluoromethane

CHLORINATED SOLVENTS:
Carbon tetrachloride
Chloroform
Ethylene Dichloride
BROMINATED SOLVENTS:
Ethylene Dibromide
Methylene chlorobromide

Methyl bromine
TRICHLOROETHANE:
Trichloroethylene
Monochlorotoluene
Chlorine (CL) “-chloro-”
Iodine (I) “-iodo-”
METHYLENE CHLORIDE
OR
DICHLOROMOETHANE

Monochlorobenzene
Orthodichlorobenzene
Porchloroethylene
IODINATED SOLVENTS:
N-butyl iodide
Methyl iodide
Ethyl iodide
Propyl iodide

OPERATING INSTRUCTIONS FOR SERIES 8000 HVLP SPRAY GUNS FOR COMPRESSED AIR

CONGRATULATIONS!! You have just purchased the finest HVLP compressed air spray gun available. You are about to enjoy the great benefits of TrueHVLP™. Our designs are the result of many years experience in manufacturing HVLP spray guns. We have painstakingly worked and consulted with professional spray finishers to bring you this versatile, well engineered tool.

Whether you are new to spray finishing, you have spray finished before, or are just new to HVLP spraying, there are some basic spray finishing guide lines that will help you to achieve the best results and optimum success from your new equipment. Reading this information carefully and following these simple steps will ensure that you get the best performance and results from your new TrueHVLP™ spray gun.

INSTRUCTIONS

Check the contents of your box. The following are included:
Spray gun Instruction Manual Wrench (Spanner)

IDENTIFY YOUR MODEL HVLP SPRAY GUN



8000



8200



8400

Operating Instructions HVLP Spray Gun Model A8000 (Gravity Feed HVLP Spray Gun)

- The A8000 HVLP Spray Gun is designed for use with a standard air compressor. It is recommended to use a 3hp compressor with a 20 gallon (75 liter) tank or larger. Smaller compressors may not provide enough continuous air pressure causing production delay while the air reservoir replenishes.
 - The A8000 HVLP Spray Gun is supplied standard with a 1.5mm fluid nozzle (2), fluid needle (7) and air cap (1). This should be appropriate for most automotive spray applications and other medium viscosity fluids. A larger 1.8mm set is available for additional flow with a higher viscosity fluid. The air connector (25) is ¼" (.635cm)
1. Attach 600cc spray gun cup (26) to the threaded opening on the top of the spray gun body as shown by the broken line in Diagram A.
 2. If desired, attach optional pressure gauge and regulator (see optional accessories) to air connector (25) and then connect air compressor line either to the pressure gauge and regulator or directly to the air connector (25) if no regulator or gauge is used.

3. Unscrew lid of paint cup and add the desired amount of fluid to be sprayed. Be sure to mix paint properly to manufacturers recommendations for best results.
4. Regulate air pressure to 43psi (3 bar). This will create 10psi (.69 bar) at the nozzle. Note: To operate as a TrueHVLP spray gun, do not exceed 10psi (.69 bar). Adjust pressure down if necessary for the most efficient results.
5. Squeeze the trigger until it meets resistance. This opens the air valve. Pulling the trigger back past the resistance pulls the fluid needle back from the nozzle releasing fluid, which is then atomized by the compressed air flowing from the air cap.
6. Hold the spray gun approximately 6" (15cm) from the surface to be sprayed. Adjust the amount of fluid by turning the fluid control knob (9) anti-clockwise. Begin with two full turns. Adjust more or less as needed based on distance of the spray gun from the surface to be sprayed and the viscosity of the fluid. Average operating distance for the spray gun is 4" (10cm) – 8" (20cm).
7. Locate the round control knob (23) on the left side of the spray gun. Rotate the control knob fully anti-clockwise. This will provide a full, flat spray pattern. As you rotate the control knob clockwise, the pattern will become smaller until the pattern is practically round. Adjust pattern as needed. If in doubt, always leave control knob in full open position.
8. See Diagram D for proper spraying technique and movement of the spray gun.

A8000 HVLP Spray Gun Maintenance

1. **Changing the nozzle set.** Always change the complete nozzle set whenever changing nozzle size. There are three components. The air cap, fluid nozzle and fluid needle. They are supplied as a complete set. Always insert the fluid nozzle before the fluid needle.
2. **Replacement of the self-adjusting paint needle packing.** For replacement of the self-adjusting paint needle packing the fluid needle (7) must be removed. Insert the hollow key with its cylindrical connection (supplied with spray gun) into the spray gun instead of the paint needle and unscrew the gland nut, gland seal spring and gland seal (4,5,6). To replace, push gland nut, gland seal spring and new gland seal (4,5,6) onto the cylindrical connection of the hollow key and screw them tight inside the gun body. Use this opportunity to inspect the fluid needle, clean and lubricate if necessary before reinstalling into spray gun.
3. **Cleaning the A8000 HVLP Spray Gun.** Pour any unused fluid from the spray gun gravity feed cup into a safe container when finished working. Fill the paint cup half way with appropriate solvent or cleaning fluid. Spray the cleaner through the spray gun discharging the fluid safely. Wipe the cup clean. Carefully clean fluid nozzle and air cap with a soft brush. Never use sharp objects to clean any holes or orifices in the spray gun as damage to these parts can severely affect the proper operation of the spray gun. (See A5318 Spray Gun Cleaning Kit – Optional Accessories).
4. **Lubrication.** As part of routine maintenance, use silicone free spray gun lube or similar material. Put a spot of lubricating material on all threaded parts to maintain smooth operation. In addition, a spot of lubricating material on the fluid needle where it passes through the gland nut will prevent the needle from sticking and insure easy movement of the trigger and fluid needle operation.

Operating Instructions HVLP Spray Gun Model 8200 (Tri-Mode)

The A8200 HVLP Spray Gun is designed for use with a standard air compressor. It is recommended to use a 3hp compressor with a 20 gallon (75 liter) tank or larger. Smaller compressors may not provide enough continuous air pressure causing production delay while the air reservoir replenishes.

The A8200 HVLP Spray Gun is supplied standard with a 1.4mm fluid nozzle (3), fluid needle (17) and air cap (1). This should be appropriate for most industrial spray applications and medium viscosity fluids. Two additional sets are available. 1.0mm and 2.0mm. These are supplied as complete sets (fluid nozzle, fluid needle and air cap) and must be used as a complete set. The air inlet (32) is ¼" (.635cm)

1. The A8200 HVLP Spray Gun offers the finisher three options. (Tri-mode). The spray gun has an optional 700cc standard mount siphon cup, an optional 400cc side mount gravity feed cup or it can be used without any cup as a production style spray gun with fluid hose to a remote pressure pot. (See optional accessories). When you receive the spray gun the side mount fluid connector (33) will be capped (34) with a material inlet cap. This can be removed and installed on the fluid connector (27) if you are going to use the side mount 400cc gravity feed spray cup.
2. First, select the mode you are going to operate the spray gun. Install either the optional 700cc siphon cup or the optional 400cc side mount gravity cup or if you are not using a cup install a fluid hose on the fluid connector (27).
3. Familiarize yourself with the controls of the spray gun. (See Diagram B) First, is the fan pattern control ring (8). This is the black ring on the front of the spray gun behind the large black air cap ring. Rotate the ring fully anti-clockwise. In this position you will have a full flat spray pattern. As you rotate the ring clockwise, the pattern will get smaller until it becomes round. Use this ring to adjust your pattern size as needed. In addition, as you move the spray gun closer or further from the work surface, the pattern size will also get smaller or larger. Now, locate the Valve Assembly (22). This control will fine tune the air adjustment and atomization as needed. This control will aid in automotive finishing when blending or touch-up is desired.
4. If desired, attach optional pressure gauge and regulator (see optional accessories) to air connector (32) and then connect air compressor line either to the pressure gauge and regulator or directly to the air connector (32) if no regulator or gauge is used.
5. If you are using one of the optional spray gun cups, add the desired amount of fluid to be sprayed. Be sure to mix paint properly to manufacturers recommendations for best results. If using from a remote pressure pot, prepare paint as recommended, close pressure pot tight and connect a proper fluid hose from the paint pot to the fluid connector (27) on the A8200 spray gun.
6. Regulate air pressure to the spray gun to 32psi (2.20 bar). This will create 10psi (.69 bar) at the nozzle. Note: To operate as a TrueHVLP spray gun, do not exceed 10psi (.69 bar). Adjust pressure down if necessary for the most efficient results.
7. Squeeze the trigger until it meets resistance. This opens the air valve. Pulling the trigger back past the resistance pulls the fluid needle back from the nozzle releasing fluid, which is then atomized by the compressed air flowing from the air cap.

8. Hold the spray gun approximately 6" (15cm) from the surface to be sprayed. Adjust the amount of fluid by turning the fluid control knob (21) anti-clockwise. Begin with two full turns. Adjust more or less as needed based on distance of the spray gun from the surface to be sprayed and the viscosity of the fluid. Average operating distance for the spray gun is 4" (10cm) – 8" (20cm).
9. Adjust the pattern control ring (8) and fine tune air volume with the air valve assembly (22) if necessary. If in doubt, always use both controls in full open position.
10. See Diagram D for proper spraying technique and movement of the spray gun.

A8200 HVLP Spray Gun Maintenance

1. **Changing the nozzle set.** Always change the complete nozzle set whenever changing nozzle size. There are three components. The air cap, fluid nozzle and fluid needle. They are supplied as a complete set. Always insert the fluid nozzle before the fluid needle.
2. **Cup Gasket.** If leakage occurs around the cup lid, first check to be sure the cup is installed tight and that all surfaces are clean and free of dried material. If necessary, replace white gasket. Carefully remove the installed gasket. Clean all surfaces where gasket sits and push new gasket in place making sure to seat the gasket evenly on all surfaces. Reinstall the cup to seat the gasket.
3. **Cleaning the A8200 HVLP Spray Gun with cup assembly installed.** Pour any unused fluid from the spray gun cup into a safe container when finished working. Fill the paint cup half way with appropriate solvent or cleaning fluid. Spray the cleaner through the spray gun discharging the fluid safely. Wipe the cup clean. Carefully clean fluid nozzle and air cap with a soft brush. Never use sharp objects to clean any holes or orifices in the spray gun as damage to these parts can severely affect the proper operation of the spray gun. (See A5318 Spray Gun Cleaning Kit – Optional Accessories).
4. **Cleaning the A8200 HVLP Spray Gun without cup assembly.** Release pressure in remote paint pot. Pull trigger of spray gun to back pressure any paint in the fluid line. Flush paint pot and fluid line discharging the fluid safely. Carefully clean fluid nozzle and air cap with a soft brush. Never use sharp objects to clean any holes or orifices in the spray gun as damage to these parts can severely affect the proper operation of the spray gun. (See A5318 Spray Gun Cleaning Kit – Optional Accessories).
5. **Lubrication.** As part of routine maintenance, use silicone free spray gun lube or similar material. Put a spot of lubricating material on all threaded parts to maintain smooth operation. In addition, a spot of lubricating material on the fluid needle where it passes through the gland nut will prevent the needle from sticking and insure easy movement of the trigger and fluid needle operation.

Operating Instructions HVLP Spray Gun Model A8400 (Tri-mode)

The A8400 HVLP Spray Gun is designed for use with a standard air compressor. It is recommended to use a 3hp compressor with a 20 gallon (75 liter) tank or larger. Smaller compressors may not provide enough continuous air pressure causing production delay while the air reservoir replenishes.

The A8400 HVLP Spray Gun is supplied standard with a 1.3mm fluid nozzle (2), fluid needle (7) and air cap (1). This should be appropriate for most industrial spray applications and medium viscosity fluids. Two additional sets are available. 1.0mm and 1.5mm. These are supplied as complete sets (fluid nozzle, fluid needle and air cap) and must be used as a complete set. The air inlet (23) is ¼" (.635cm)

1. The A8400 HVLP Spray Gun offers the finisher three options. (Tri-mode). The spray gun has an optional 700cc standard mount siphon cup, an optional 400cc side mount gravity feed cup or it can be used without any cup as a production style spray gun with fluid hose to a remote pressure pot. (See optional accessories). When you receive the spray gun the side mount fluid connector (14) will be capped (15) with a material inlet cap. This can be removed and installed on the fluid connector (13) if you are going to use the side mount 400cc gravity feed spray cup.
2. First, select the mode you are going to operate the spray gun. Install either the optional 700cc siphon cup or the optional 400cc side mount gravity cup or if you are not using a cup install a fluid hose on the fluid connector (13).
3. Familiarize yourself with the controls of the spray gun. First, is the fan pattern control (10). (See Diagram C) Rotate the control anti-clockwise all the way. In this position you will have a full flat spray pattern. As you rotate the control clockwise, the pattern will get smaller. Use this control to adjust your pattern size as needed. In addition, as you move the spray gun closer or further from the work surface, the pattern size will also get smaller or larger. Now, locate the Air Adjusting Valve (22). This control will fine tune the air adjustment and atomization as needed. This control will aid in automotive finishing when blending or touch-up is desired.
4. If desired, attach optional pressure gauge and regulator (see optional accessories) to air connector (13) and then connect air compressor line either to the pressure gauge and regulator or directly to the air connector (13) if no regulator or gauge is used.
5. If you are using one of the optional spray gun cups, add the desired amount of fluid to be sprayed. Be sure to mix paint properly to manufacturers recommendations for best results. If using from a remote pressure pot, prepare paint as recommended, close pressure pot tight and connect a proper fluid hose from the paint pot to the fluid connector (13) on the A8400 spray gun.
6. Regulate air pressure to the spray gun to 43psi (3 bar). This will create 10psi (.69 bar) at the nozzle. Note: To operate as a TrueHVLP spray gun, do not exceed 10psi (.69 bar). Adjust pressure down if necessary for the most efficient results.
7. Squeeze the trigger until it meets resistance. This opens the air valve. Pulling the trigger back past the resistance pulls the fluid needle back from the nozzle releasing fluid, which is then atomized by the compressed air flowing from the air cap.

8. Hold the spray gun approximately 6" (15cm) from the surface to be sprayed. Adjust the amount of fluid by turning the fluid control knob (21) anti-clockwise. Begin with two full turns. Adjust more or less as needed based on distance of the spray gun from the surface to be sprayed and the viscosity of the fluid. Average operating distance for the spray gun is 4" (10cm) – 8" (20cm).
9. Adjust the fan control (10) and fine tune air volume with the air valve assembly (22) if necessary. If in doubt, always use both controls in full open position.
10. See Diagram D for proper spraying technique and movement of the spray gun.

A8400 HVLP Spray Gun Maintenance

1. **Changing the nozzle set.** Always change the complete nozzle set whenever changing nozzle size. There are three components. The air cap, fluid nozzle and fluid needle. They are supplied as a complete set. Always insert the fluid nozzle before the fluid needle.
2. **Cup Gasket.** If leakage occurs around the cup lid, first check to be sure the cup is installed tight and that all surfaces are clean and free of dried material. If necessary, replace white gasket. Carefully remove the installed gasket. Clean all surfaces where gasket sits and push new gasket in place making sure to seat the gasket evenly on all surfaces. Reinstall the cup to seat the gasket.
3. **Cleaning the A8400 HVLP Spray Gun with cup assembly installed.** Pour any unused fluid from the spray gun cup into a safe container when finished working. Fill the paint cup half way with appropriate solvent or cleaning fluid. Spray the cleaner through the spray gun discharging the fluid safely. Wipe the cup clean. Carefully clean fluid nozzle and air cap with a soft brush. Never use sharp objects to clean any holes or orifices in the spray gun as damage to these parts can severely affect the proper operation of the spray gun. (See A5318 Spray Gun Cleaning Kit – Optional Accessories).
4. **Cleaning the A8400 HVLP Spray Gun without cup assembly.** Release pressure in remote paint pot. Pull trigger of spray gun to back pressure any paint in the fluid line. Flush paint pot and fluid line discharging the fluid safely. Wipe the cup clean. Carefully clean fluid nozzle and air cap with a soft brush. Never use sharp objects to clean any holes or orifices in the spray gun as damage to these parts can severely affect the proper operation of the spray gun. (See A5318 Spray Gun Cleaning Kit – Optional Accessories).
5. **Lubrication.** As part of routine maintenance, use silicone free spray gun lube or similar material. Put a spot of lubricating material on all threaded parts to maintain smooth operation. In addition, a spot of lubricating material on the fluid needle where it passes through the gland nut will prevent the needle from sticking and insure easy movement of the trigger and fluid needle operation.

DIAGRAM A

***HVLP Spray Gun
Model A8000***

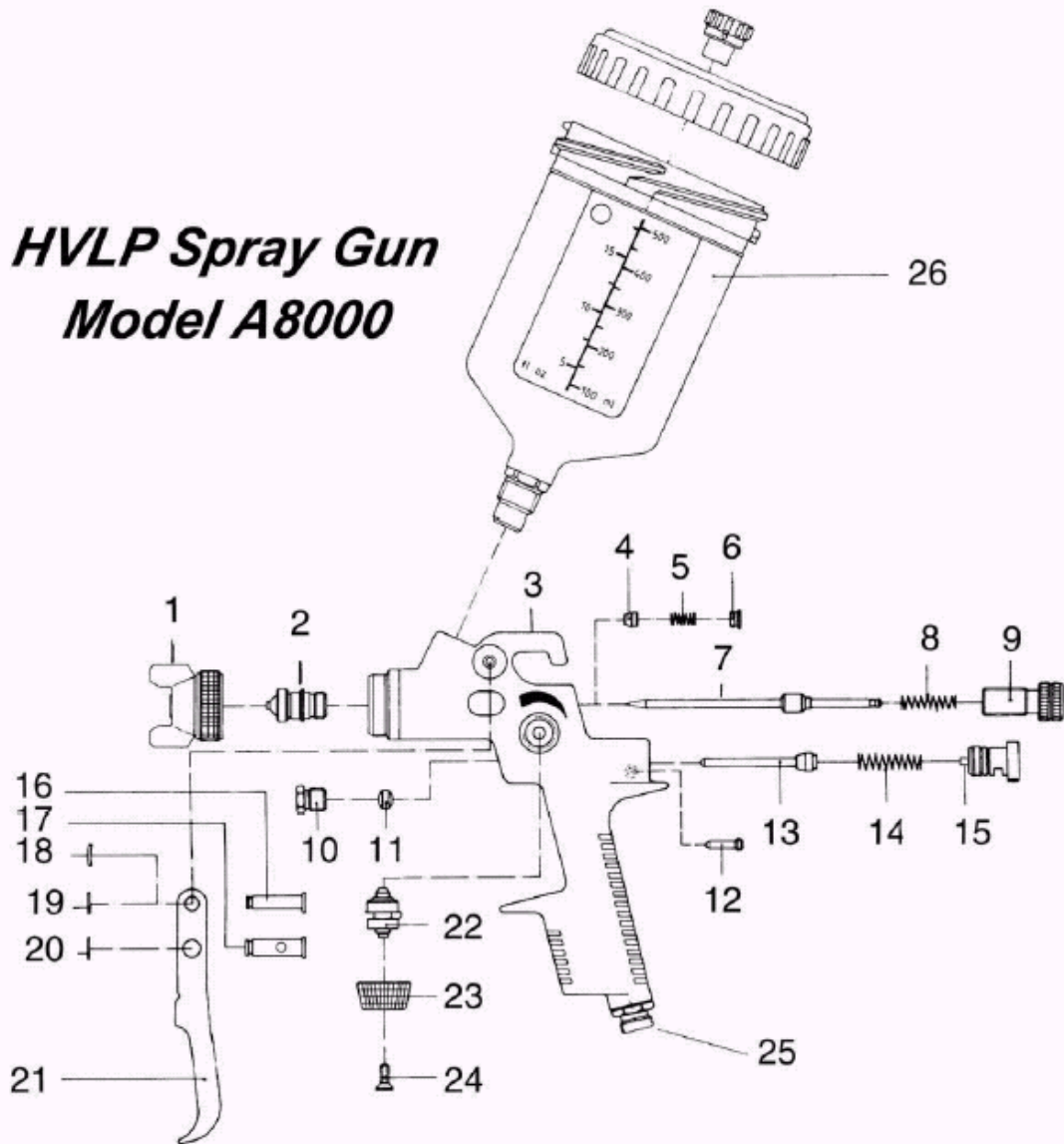

Item #	Description	Part #	Item #	Description	Part #
1	AIR CAP WITH RING - 1.5mm	A8021	13	AIR VALVE PISTON	A8036
1	AIR CAP WITH RING - 1.8mm	A8022	14	AIR VALVE SPRING	A8037
2	FLUID NOZZLE - 1.5mm	A8023	15	BLANKING CAP	A8038
2	FLUID NOZZLE - 1.8mm	A8024	16	TRIGGER PIVOT SCREW	A8039
3	GUN BODY	A8025	17	TRIGGER PIVOT SLEEVE	A8040
4	GLAND SEAL	A8026	18	SPRING WASHER	A8041
5	GLAND SEAL SPRING	A8027	19	UPPER TRIGGER CLIP	A8042
6	GLAND NUT	A8028	20	LOWER TRIGGER CLIP	A8043
7	FLUID NEEDLE - 1.5mm	A8029	21	TRIGGER	A8044
7	FLUID NEEDLE - 1.8mm	A8030	22	FAN CONTROL VALVE	A8045
8	NEEDLE RETURN SPRING	A8031	23	FAN CONTROL KNOB	A8046
9	FLUID CONTROL KNOB	A8032	24	PHILLIPS SCREW	A8047
10	AIR VALVE SEALING NUT	A8033	25	AIR CONNECTOR	A8048
11	AIR VALVE SEALING GASKET	A8034	26	600CC CUP COMPLETE	A6800
12	SET SCREW	A8035			

DIAGRAM B

**HVLP Spray Gun
Model A8200**

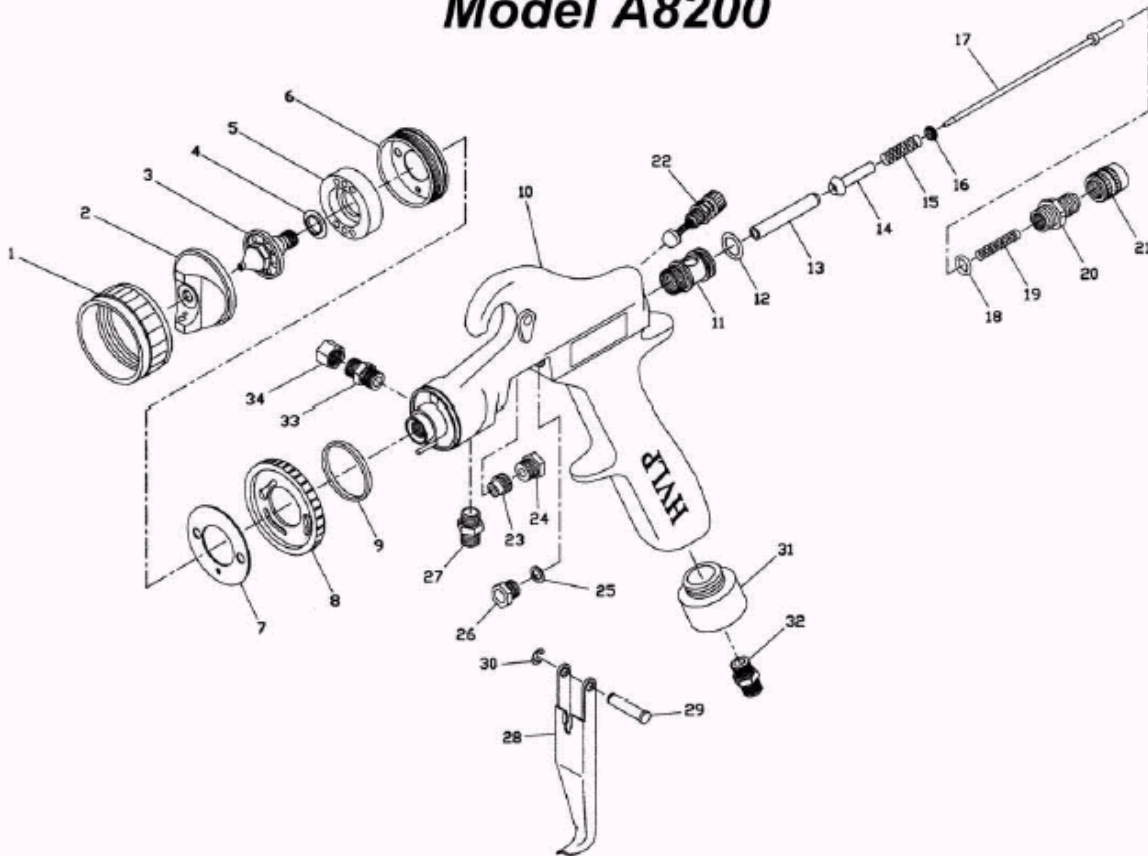

#	DESCRIPTION	PART #	#	DESCRIPTION	PART #
1	AIR CAP RING	A8221	17	FLUID NEEDLE 1.0mm	A8241
2	AIR CAP 1.0mm	A8222	17	FLUID NEEDLE 1.4mm	A8242
2	AIR CAP 1.4mm	A8223	17	FLUID NEEDLE 2.0mm	A8243
2	AIR CAP 2.0mm	A8224	18	O RING	A8244
3	FLUID NOZZLE 1.0mm	A8225	19	NEEDLE SPRING	A8245
3	FLUID NOZZLE 1.4mm	A8226	20	FLOW SCREW BUSHING	A8246
3	FLUID NOZZLE 2.0mm	A8227	21	FLOW ADJ. SCREW	A8247
4	NOZZLE GASKET	A8228	22	VALVE ASSEMBLY	A8248
5	AIR DISTRIBUTOR RING	A8229	23	GLAND SEAL	A8249
6	AIR DISTRIBUTOR HOUSING	A8230	24	GLAND SEAL ADJ. SCREW	A8250
7	AIR DISTRIBUTOR PLATE	A8231	25	O RING	A8251
8	FAN PATTERN CONTROL	A8232	26	LOCK NUT	A8252
9	TEFLON GASKET	A8233	27	FLUID CONNECTOR	A8253
10	GUN BODY W/ FLUID NOZZLE TUBE & INSET PIN	A8234	28	TRIGGER	A8254
11	AIR VALVE BUSHING	A8235	29	TRIGGER PIVOT	A8255
12	O RING	A8236	30	RETAINING CLIP	A8256
13	PIN PLUNGER	A8237	31	AIR INLET ADAPTER	A8257
14	PILOT VALVE	A8238	32	AIR INLET 1/4"	A8258
15	AIR VALVE SPRING	A8239	33	FLUID CONNECTOR	A8253
16	NEEDLE WASHER	A8240	34	MATERIAL INLET CAP	A8259

DIAGRAM C

**HVLP Spray Gun
Model 8400**

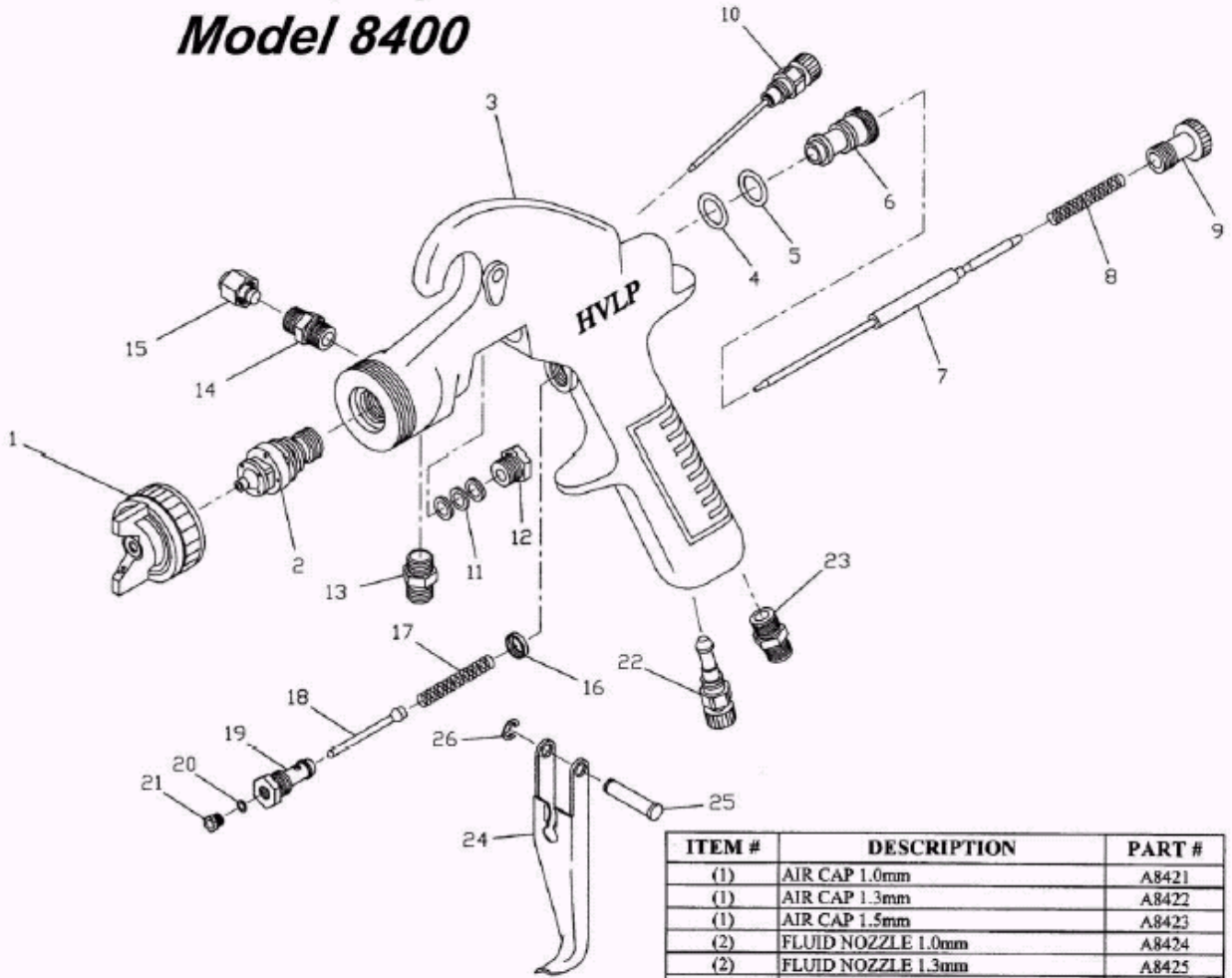

ITEM #	DESCRIPTION	PART #
(1)	AIR CAP 1.0mm	A8421
(1)	AIR CAP 1.3mm	A8422
(1)	AIR CAP 1.5mm	A8423
(2)	FLUID NOZZLE 1.0mm	A8424
(2)	FLUID NOZZLE 1.3mm	A8425
(2)	FLUID NOZZLE 1.5mm	A8426
(3)	GUN BODY	A8427
(4)	GASKET	A8428
(5)	O RING	A8429
(6)	NEEDLE VALVE GUIDE	A8430
(7)	FLUID NEEDLE 1.0mm	A8431
(7)	FLUID NEEDLE 1.3mm	A8432
(7)	FLUID NEEDLE 1.5mm	A8433
(8)	NEEDLE SPRING	A8434
(9)	FLUID ADJUSTING KNOB	A8435
(10)	FAN ADJUSTING VALVE SET	A8436
(11)	GLAND SEAL (3 required)	A8437
(12)	GLAND NUT	A8438
(13)	FLUID CONNECTOR	A8439
(14)	FLUID CONNECTOR	A8439
(15)	MATERIAL INLET CAP	A8440
(16)	TRIGGER AIR VALVE GASKET	A8441
(17)	AIR VALVE SPRING	A8442
(18)	AIR VALVE NEEDLE	A8443
(19)	AIR VALVE SEAL	A8444
(20)	TRIGGER AIR VALVE GLAND SEAL	A8437
(21)	TRIGGER AIR VALVE GLAND NUT	A8445
(22)	AIR ADJUSTING VALVE SET	A8446
(23)	AIR HOSE CONNECTOR	A8447
(24)	TRIGGER	A8448
(25)	TRIGGER BUSHING	A8449
(26)	TRIGGER CIR CLIP (1)	A8450

OPTIONAL ACCESSORIES



A6700 - 400cc GRAVITY
FEED CUP FOR A8200 AND
A8400 SPRAY GUNS



A6900 - 700CC
SIPHON CUP FOR
A8200 AND A8400
SPRAY GUNS



A4251 - MINI
AIR REGULATOR
WITHOUT GAUGE



A4253 - AIR
REGULATOR WITH
GAUGE



A4252 - WALL MOUNT FILTER
AND AIR REGULATOR



A4421 - 2 QUART (2 LITER)
PRESSURE POT



A4166 - 2 1/2 GALLON
(10 LITER) PRESSURE POT



A5318 - 17 PIECE SPRAY
GUN CLEANING KIT



A2116 CUSTOM AIR HOSE



A2117 CUSTOM FLUID HOSE

DIAGRAM D - SPRAYING TECHNIQUE

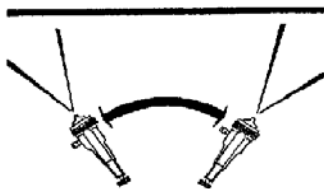

WRONG

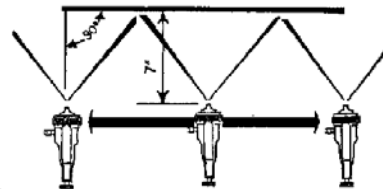

RIGHT

TROUBLESHOOTING

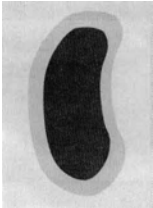
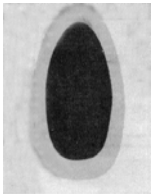
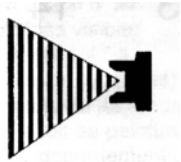
PROBLEM	CAUSE	REPAIR
SPRAY GUN LEAKS FROM FLUID TIP	FOREIGN OBJECT BETWEEN FLUID TIP AND NEEDLE PREVENT SEALING	CLEAN FLUID NEEDLE AND FLUID NOZZLE IN SOLVENT OR USE NEW NOZZLE SET. CHECK GLAND NUT. LOOSEN IF NECESSARY.
SPRAY PATTERN IN SICKLE SHAPE 	AIR CAP HOLES CLOGGED	CLEAN WITH APPROPRIATE SOLVENT AND SOFT BRUSH
DROP-LIKE OR OVAL SHAPED PATTERN 	DIRT ON FLUID NOZZLE OR AIR OUTLET	TURN AIR CAP 180°. IF DEFECTIVE PATTERN REMAINS, CLEAN FLUID NOZZLE AND AIR CAP HOLES.
PAINT SPRAY FLUTTERS 	NOT ENOUGH MATERIAL IN PAINT CUP. FLUID NOZZLE NOT TIGHT.	FILL PAINT CUP WITH MORE FLUID. TIGHTEN ALL PARTS IF NECESSARY
MATERIAL BUBBLES OR BOILS IN PAINT CUP	FLUID NOZZLE NOT SUFFICIENTLY TIGHT. AIR CAP NOT COMPLETELY SCREWED TIGHT.	TIGHTEN PARTS ACCORDINGLY, CLEAN OR REPLACE IF NECESSARY.

FOR SERVICE AND MAINTENANCE CALL

